



# ENERGY

POWER SUPPLIER PROJECT SOLUTIONS



**SHENZHEN MAX POWER CO.,LTD**

[www.szmaxpower.com](http://www.szmaxpower.com)

# 48V50Ah



Nominal Capacity	50.0Ah
Nominal Voltage	51.2V
Standard Charging Refer to 3.1	10A 57.6V 0.2A
Charging Voltage	57.6V
Max. Continuous Charge Current	25.0A
Standard Discharging Refer to 3.2	25.0A 43.2V
Max Continuous Discharge Current	50.0A
Max Output Power	2.56KW

# 48V100Ah



Nominal Capacity	100.0Ah
Nominal Voltage	51.2V
Standard Charging Refer to 3.1	20A 57.6V 0.5A
Charging Voltage	57.6V
Max. Continuous Charge Current	50.0A
Standard Discharging Refer to 3.2	50.0A 43.2V
Max Continuous Discharge Current	100.0A
Max Output Power	5.12KW

# 48V150Ah



Nominal Capacity	150.0Ah
Nominal Voltage	51.2V
Standard Charging Refer to 3.1	30A 57.6V 0.7A
Charging Voltage	57.6V
Max. Continuous Charge Current	75.0A
Standard Discharging Refer to 3.2	75.0A 43.2V
Max Continuous Discharge Current	100.0A
Max Output Power	5.12KW

# 48V200Ah



Nominal Capacity	200.0Ah
Nominal Voltage	51.2V
Standard Charging Refer to 3.1	40A 57.6V 1A
Charging Voltage	57.6V
Max. Continuous Charge Current	100.0A
Standard Discharging Refer to 3.2	75.0A 43.2V
Max Continuous Discharge Current	100.0A
Max Output Power	5.12KW

## 1. Product Description

This rack mode lifepo4 lithium battery belongs to one of the series of household energy storage products that are independently designed and developed. It has long cycle life, high safety standard BMS software protection and strong housing, exquisite looks, and easy installation, etc. It is widely used in energy storage system with off-grid inverters, on-off grid inverters and hybrid inverters.

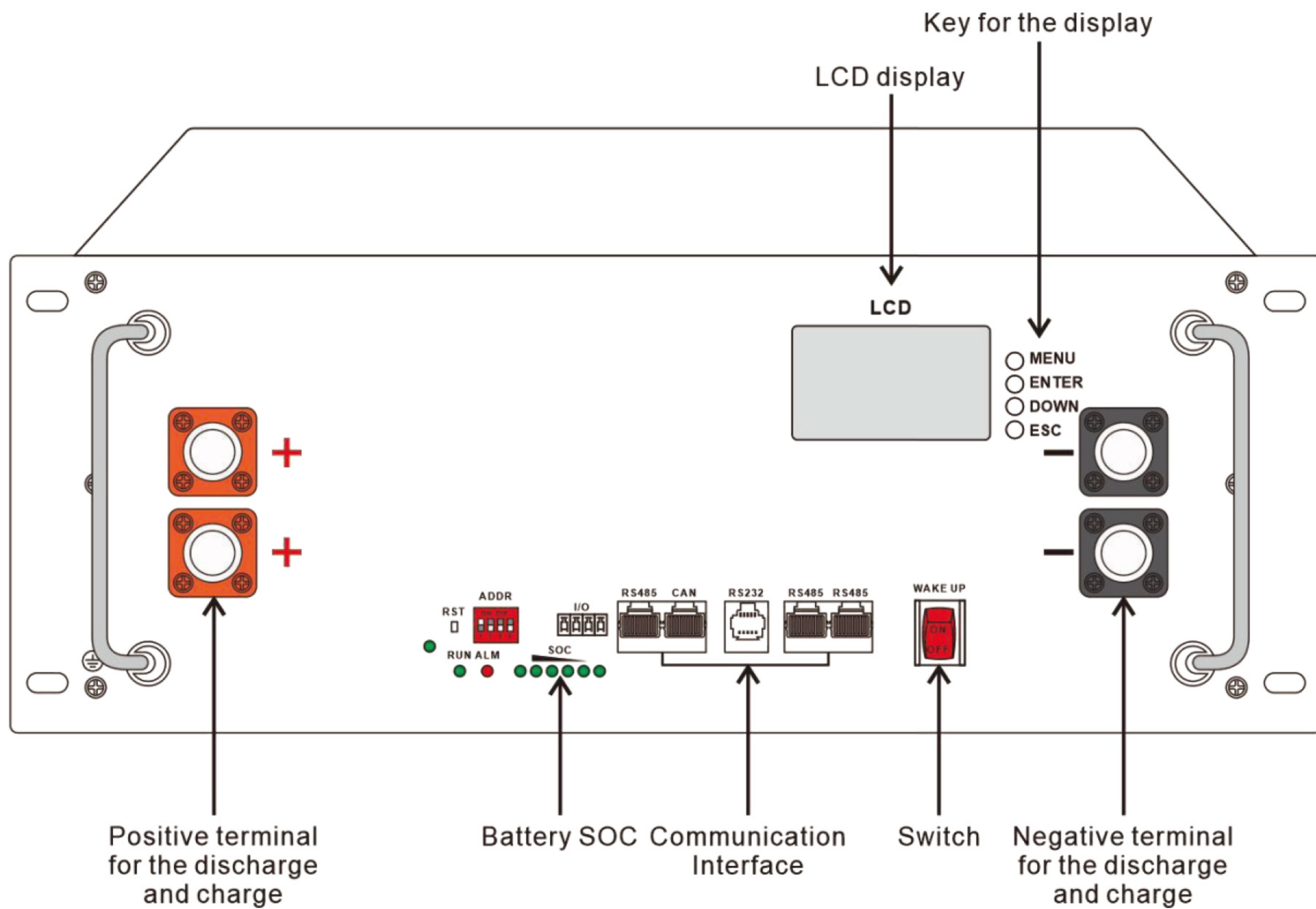

\*This interface design is only for reference, it may change according to different demands

## 2. Product Function Description

### 2.1 Product Specifications

Items		Condition	Specification			
Nominal Capacity		Standard charge/discharge	50.0Ah	100.0Ah	150.0Ah	200.0Ah
Nominal Voltage		Average	51.2V	51.2V	51.2V	51.2V
Standard Charging Refer to 3.1		Constant current Constant voltage End current(Cut off)	10A 57.6V 0.2A	20A 57.6V 0.5A	30A 57.6V 0.7A	40A 57.6V 1A
Charging Voltage		/	57.6V	57.6V	57.6V	57.6V
Max. Continuous Charge Current		25±3℃	25.0A	50.0A	75.0A	100.0A
Standard Discharging Refer to 3.2		Constant current End voltage(Cut off)	25.0A 43.2V	50.0A 43.2V	75.0A 43.2V	100.0A 43.2V
Max Continuous Discharge Current		25±3℃	50.0A	100.0A	100.0A	100.0A
Max Output Power		25±3℃	2.56KW	5.12KW	5.12KW	5.12KW
Operating Temperature	Charge	/	0℃~ 60℃			
	Discharge	/	-20℃~ 60℃			
Storage Temperature		1 month 3 month 6 month	-20℃~ 45℃ -20℃~ 35℃ -20℃~ 25℃			
Power Cable Terminal		/	Ring Terminal			

## 2.2 Parallel Connection

When Connect the batteries in parallel, connect the positive terminal and positive terminal (red colour) in parallel, and the negative terminal and negative terminal (black colour) in parallel, the max parallel quantity is 15pcs, as shown in the figure below:

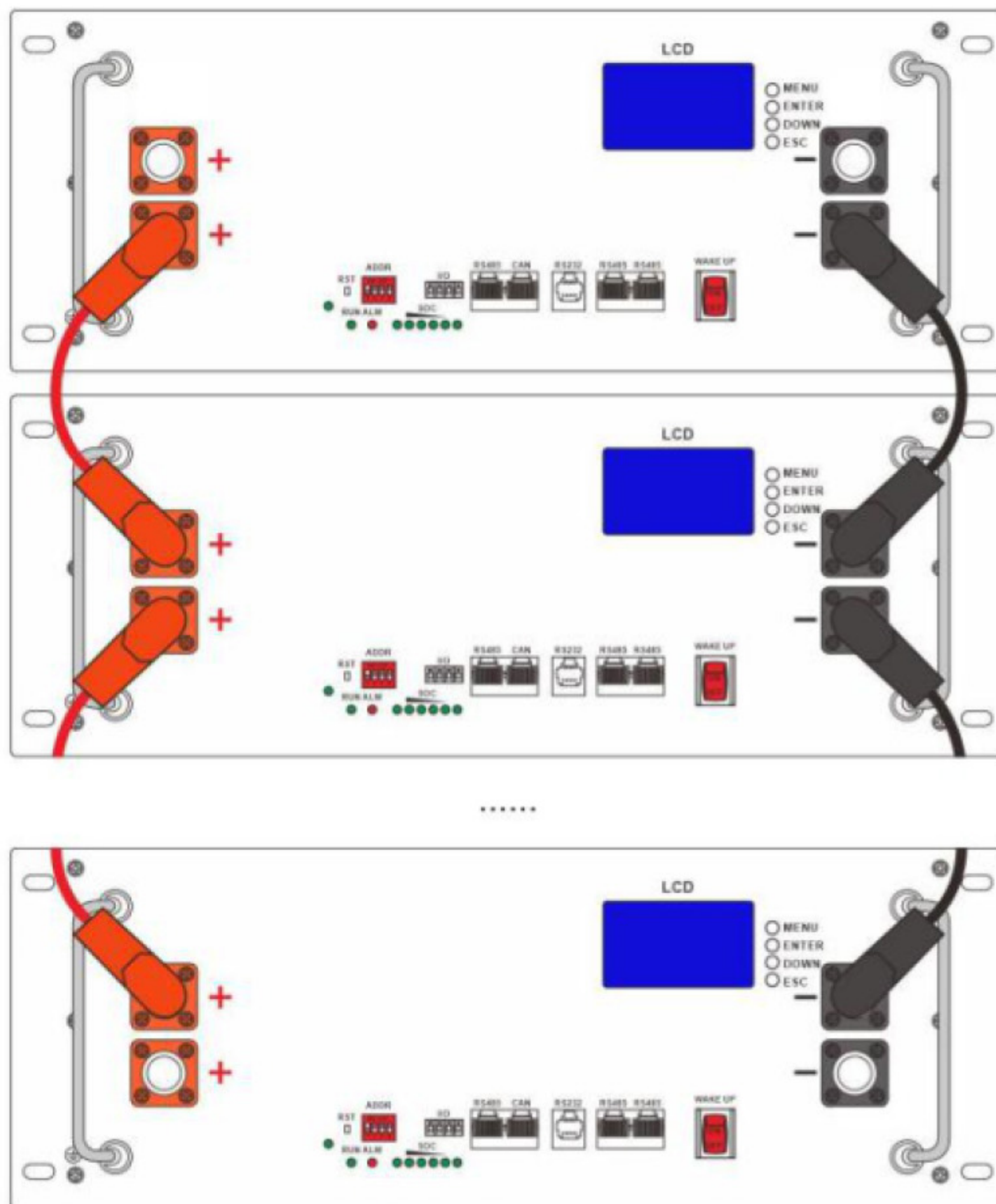

15pcs max in parallel

Model	Capacity	Max Parallel	Max Capacity
51.2V 50Ah	2.56 Kwh	15pcs	51.2V 750Ah 38.4Kwh
51.2V 100Ah	5.12 Kwh	15pcs	51.2V 1500Ah 76.8Kwh
51.2V 150Ah	7.68 Kwh	15pcs	51.2V 2250Ah 115.2Kwh
51.2V 200Ah	10.24 Kwh	15pcs	51.2V 3000Ah 153.6Kwh

## Solar System Structure

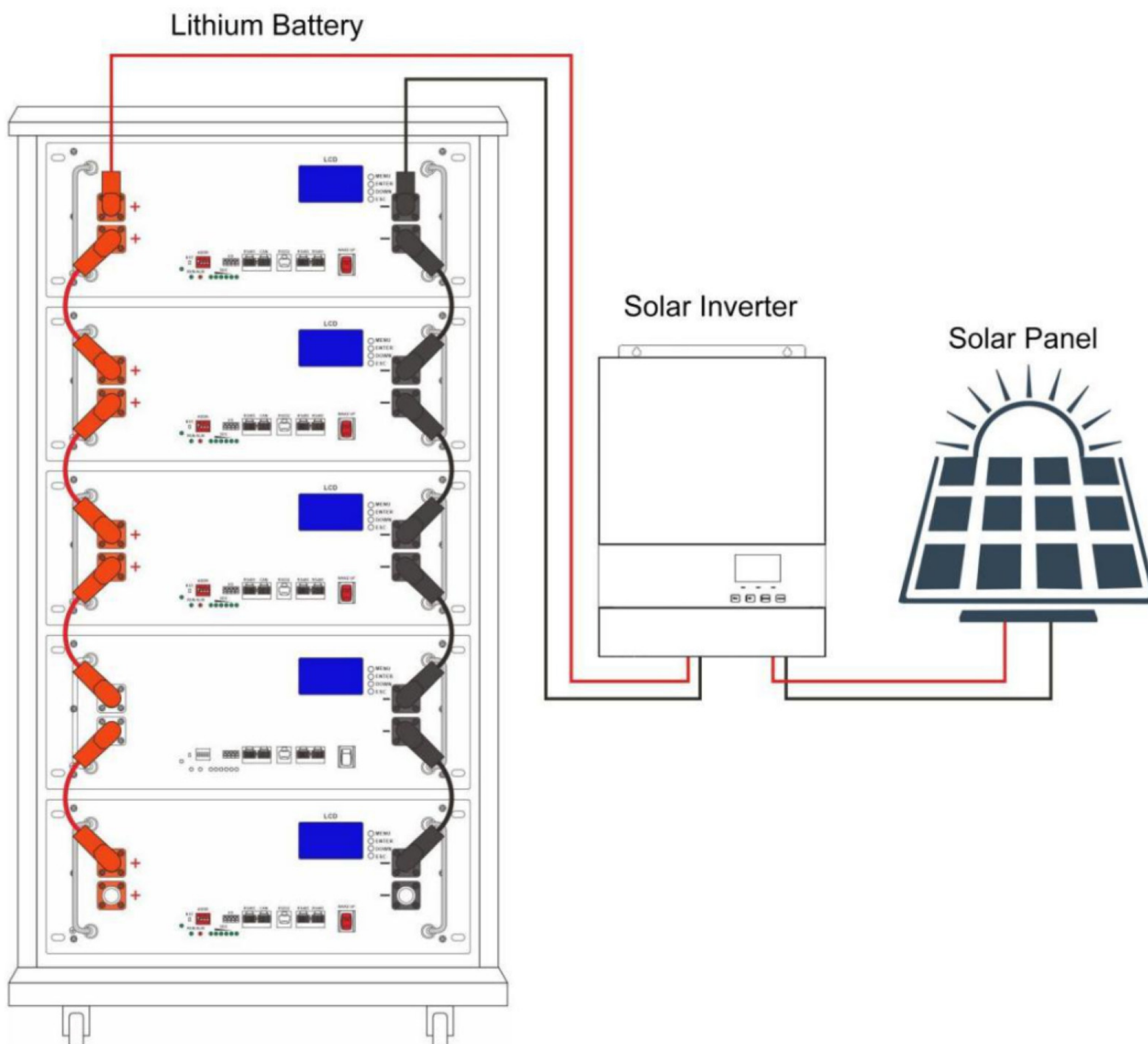

### 2.3 Dial Code Switch Settings (parallel connection needed)

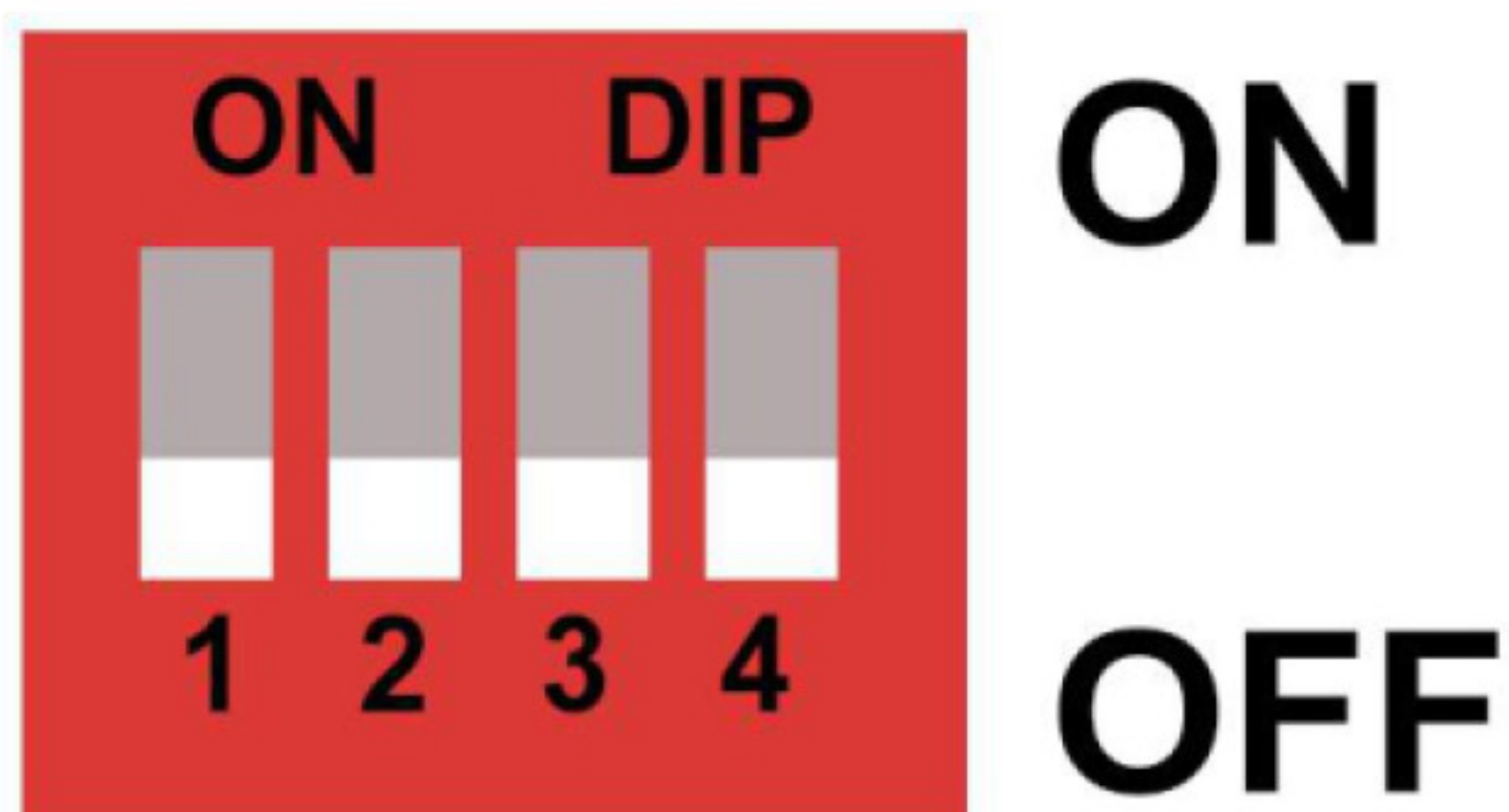

When the battery packs are connected in parallel, the dial code switch of each battery can be used to distinguish different Pack addresses. The hardware address can be set through the dial code switch on the board. The definition of the dial code switch refer to the following table.

ADD	Dial switch position				Explain
	#1	#2	#3	#4	
0	OFF	OFF	OFF	OFF	No parallel connection, only 1 pcs
1	ON	OFF	OFF	OFF	Pack1(master)
2	OFF	ON	OFF	OFF	Pack2
3	ON	ON	OFF	OFF	Pack3
4	OFF	OFF	ON	OFF	Pack4
5	ON	ON	ON	OFF	Pack5
6	OFF	ON	ON	OFF	Pack6
7	ON	ON	ON	OFF	Pack7
8	OFF	OFF	OFF	ON	Pack8
9	ON	OFF	OFF	ON	Pack9
10	OFF	ON	OFF	ON	Pack10
11	ON	ON	OFF	ON	Pack11
12	OFF	OFF	ON	ON	Pack12
13	ON	OFF	ON	ON	Pack13
14	OFF	ON	ON	ON	Pack14
15	ON	ON	ON	ON	Pack15

### 2.4 Communication Function a) RS232 communication

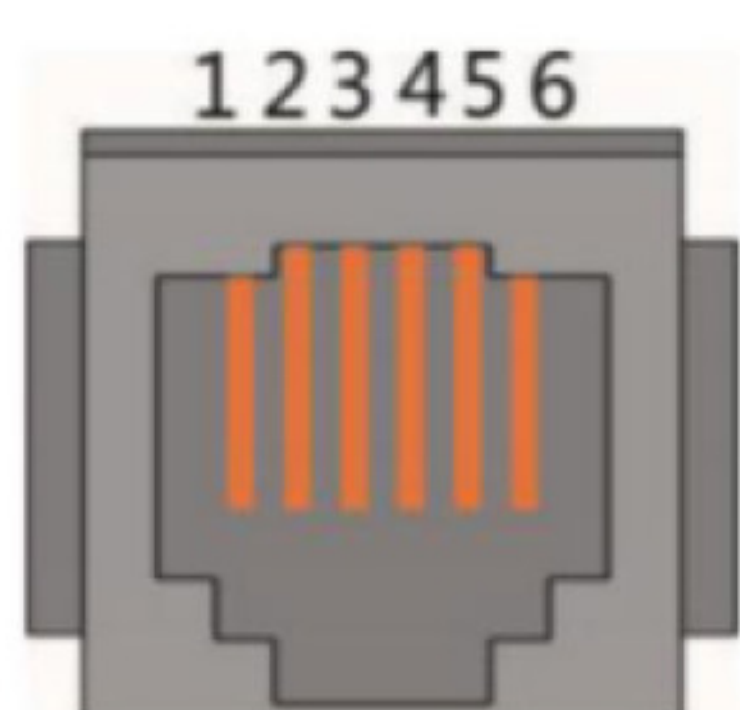

RS232 Port use 6P6C vertical RJ11 Socket	
RJ11 Pin	Define
Pin 1、 2、 6	NC(empty)
Pin 3	TX(computer receives data)
Pin 4	RX(computer sends data)
Pin 5	GND(ground)

BMS can communicate with the upper computer through RS232 interface, so that it can monitor all kinds of battery information, including battery voltage, current and temperature, working status etc. The default baud rate is 9600bps.

**b )RS485-1 / CAN main communication**

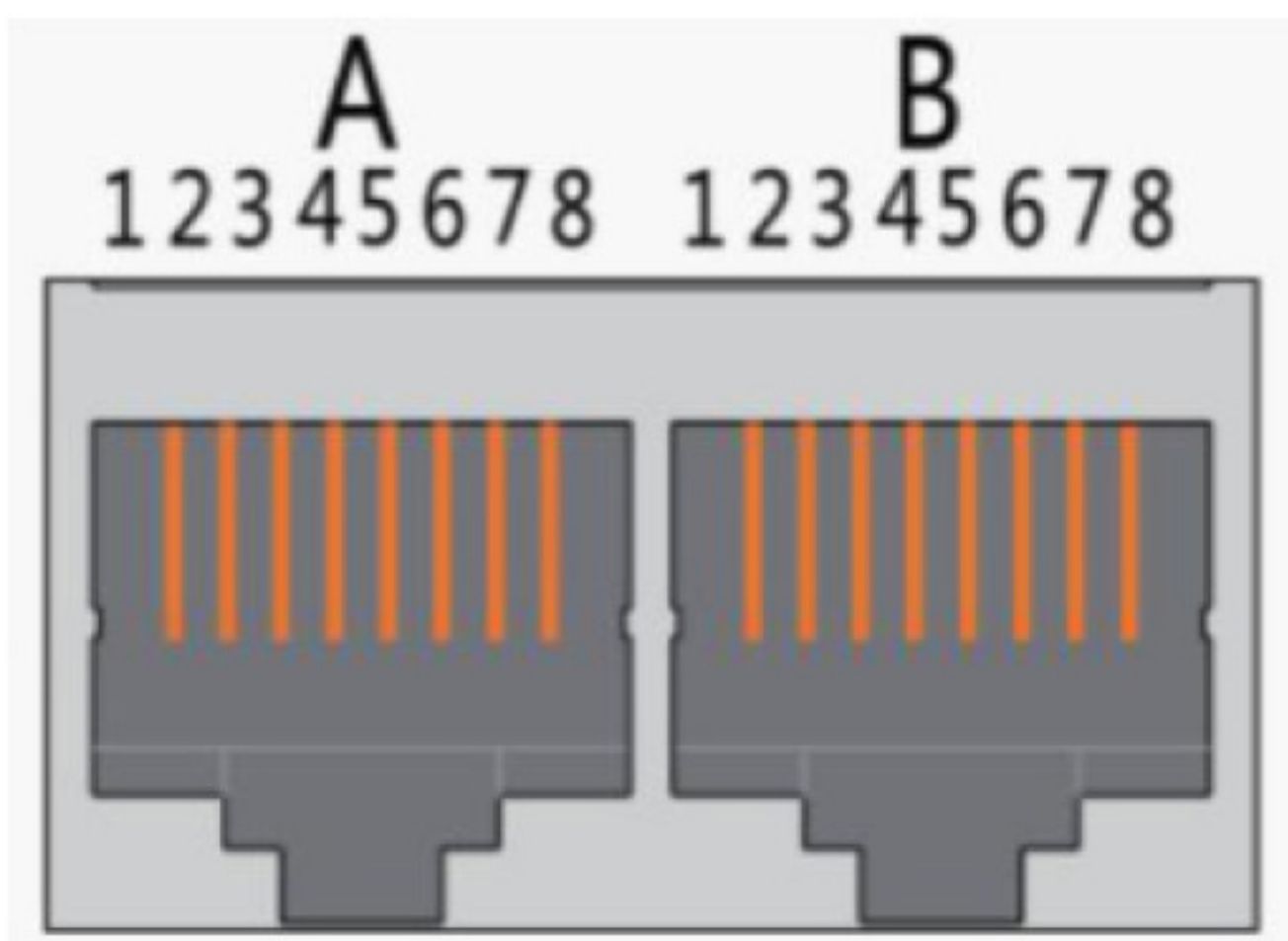

If you need to communicate with the monitoring device through RS485 or Can, the monitoring device will be used as the host, and the address setting range of other batteries will be 2~15 according to the polling data of the address.

The product adopts isolated communication design, supports RS485/CAN communication mode, RS485 communication default baud rate is 9600 bps, 8 bit data bit, 1 bit stop bit, no test bit; The default baud rate of CAN communication is 500Kbps;

RS485 & CAN use 8P8C vertical RJ45 socket			
RS485 PIN	Define	CAN PIN	Define
1、 8	RS485-B1	9、 10、 11、 14、 16	NC
2、 7	RS485-A1	12	CANL
3、 6	GND	13	CANH
4、 5	NC	15	GND

**c )RS485-2 communication for parallel connection**

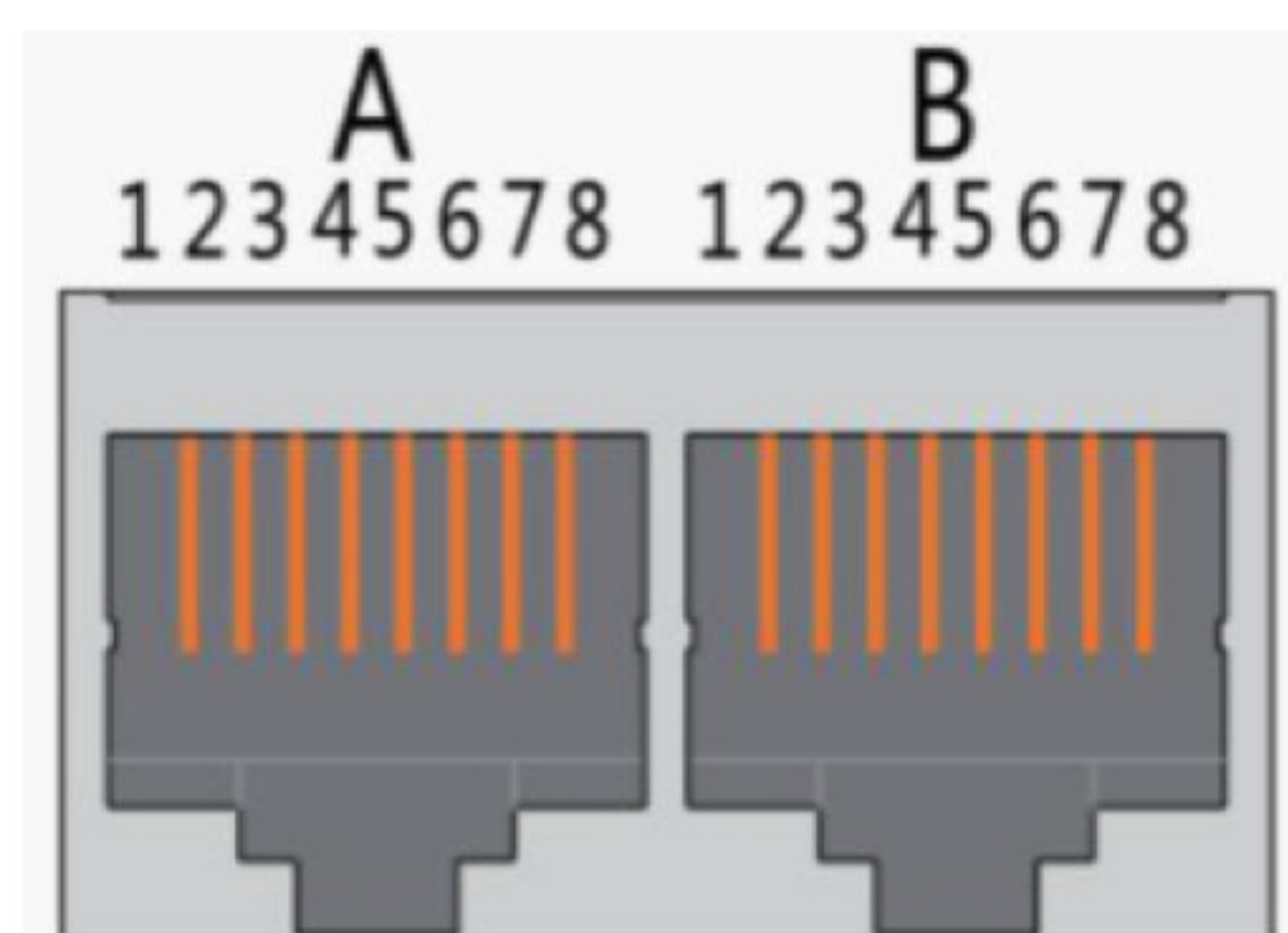

With dual RS485 interfaces, the default baud rate is 9600bps. If you need to communicate the batteries in parallel with the monitoring device or inverter, you need to connect each battery with RS485-2 ports, so the host battery can read the information of each battery.

RS485-A & RS485-B use 8P8C vertical RJ45 socket			
RS485-A PIN	Define	RS485-B PIN	Define
1、 8	RS485-B	9、 16	RS485-B
2、 7	RS485-A	10、 15	RS485-A
3、 6	GND	11、 14	GND
4、 5	NC	12、 13	NC

## 2.5 LED Indication Function

The current power consumption and operation status of the product are shown through LED indicator Light (See Table 1, Table 2, and Table 3 for details)Working status indication

Status	Normal/ warning/ protection	ON/OFF	RUN	ALM	Battery capacity LED						Specification	
		●	●	●	●	●	●	●	●	●		
Power off	Dormancy	NO	NO	NO	NO	NO	NO	NO	NO	NO	NO	All NO
Ready mode	Normal	YES	Flash1	NO	Indicate according to the battery capacity						Ready mode status	
	Warning	YES	Flash1	Flash3							Module low voltage	
Charging	Normal	YES	YES	NO	Indicate according to the battery capacity(LED 2 flash when it indicate the highest battery capacity)						LED 2 flash when it is highest battery capacity, ALM do not flash when over-charging	
	Warning	YES	YES	Flash3								
	Over charging protection	YES	YES	NO	YES	YES	YES	YES	YES	YES	YES	If there is no mains power, the indicator turns to standby
	Temperature over current, failure protection	YES	NO	YES	NO	NO	NO	NO	NO	NO	NO	Stop charging
Dis charging	normal	YES	Flash3	NO	Indicate according to the battery capacity							
	warning	YES	Flash3	Flash3								
	Under voltage protection	YES	NO	NO	NO	NO	NO	NO	NO	NO	NO	Stop discharging
	Over temperature, current, short circuit, reverse connection, failure protection	YES	NO	YES	NO	NO	NO	NO	NO	NO	NO	Stop discharging
Invalidation		NO	NO	YES	NO	NO	NO	NO	NO	NO	NO	Stop charging and discharging



## Capacity Indicator

Status		Charging						Discharging					
Capacity dictator		L6	L5	L4	L3	L2	L1	L6	L5	L4	L3	L2	L1
Battery level (%)	0~16.6%	NO	NO	NO	NO	NO	Flash2	NO	NO	NO	NO	NO	YES
	16.6~33.2%	NO	NO	NO	NO	Flash2	YES	NO	NO	NO	NO	YES	YES
	33.2~49.8%	NO	NO	NO	Flash2	YES	YES	NO	NO	NO	YES	YES	YES
	49.8~66.4%	YES	YES	Flash2	YES	YES	YES	NO	NO	YES	YES	YES	YES
	66.4~83.0%	NO	Flash2	YES	YES	YES	YES	NO	YES	YES	YES	YES	YES
	83.0~100%	Flash2	YES	YES	YES	YES	YES	YES	YES	YES	YES	YES	YES
<b>Working dictator</b> ●		YES						Flash 3					

## LED Flashing Instructions

Flash way	Bright	NO
Flash 1	0.25S	3.75S
Flash 2	0.5S	0.5S
Flash 3	0.5S	1.5S

### Note:

The LED indicator alarm can be enabled or disabled through the host computer.  
The factory default is enabled.

## 2.6 Sleep Mode

Without RS485/CAN communication, charging/discharging or pressing any buttons, 24h later this power box will enter into sleep mode to save the power, it has small self-consumption;

## 2.7 Awake Mode

When the system is in sleep mode, if any of the following requirements, the system will quit the sleep mode and enter into the normal operation mode.

- 1) Automatic wake-up after charged with voltage higher than 48V;
- 2) Press the key button for 3~6 second, release the key button and activate it;
- 3) Access communication line (RS232), activate it with upper computer software.

## 2.8 Power-off mode wake-up

- 1) Charging voltage should be greater than 52.5V.
- 2) Press the button for longer than 2 seconds and release the button.

## 2.9 This product is designed with the function of compound button.

In the normal operation process, long press this button once (>6s), then release the button and the product will be reset and restarted;

### 3. Electrical Specification

(Unless there is special requirement, the test shall be done under temperature of  $25\pm 2^{\circ}\text{C}$  and with relative humidity of 45~85%.)

Items	Test Condition				Standard
3.1 Standard Charge	The standard charge means charge the battery in temperature below $25\pm 3^{\circ}\text{C}$ with initial charge current of 10A(50Ah)/ 20A(100Ah)/ 30A(150Ah)/ 40A(200Ah) and with constant voltage of 57.6V, then charge with constant voltage of 57.6V and with floating current taper to 0.2A(50Ah)/ 0.5A(100Ah)/ 0.7A(150Ah)/ 1A(200Ah) cut-off (Charger should be exclusively designed for lithium battery, with an accuracy of $\pm 0.05\text{V}$ ) within 6 hours.				/
3.2 Standard Discharge	After battery is charged fully in accordance with the standard and then discharge to voltage 43.2V with discharge current of 10A(50Ah)/ 20A(100Ah)/ 30A(150Ah)/ 40A(200Ah).The minimum gap time between charge and discharge period is 30 minutes.				Minimum Capacity $\geq 50/100/150/200\text{Ah}$
3.3 Cycle Life	After the completion of standard charge and 30 minutes' rest, discharge with 80% DOD with constant current of 0.2C in the ( $25\pm 3^{\circ}\text{C}$ ) environment, after 3000 cycles, rest it for 1 day and test the capacity in accordance with the above 3.2				Capacity $\geq 80\%$ Minimum Capacity
3.4 Discharge Character	Discharge current	Discharge Temperature			At $-10^{\circ}\text{C}$ : Discharge Capacity $\geq 50\%$  At $0^{\circ}\text{C}$ : Discharge capacity $\geq 80\%$  At $25^{\circ}\text{C}$ Discharge capacity $\geq 100\%$  At $40^{\circ}\text{C}$ Discharge capacity $\geq 100\%$
	0.2C	$-10^{\circ}\text{C}$	$0^{\circ}\text{C}$	$25^{\circ}\text{C}$ $40^{\circ}\text{C}$	
	Batteries shall be charged according to 3.1 and discharged in accordance with the above mentioned temperature. The discharge capacity shall meet the standard. Batteries shall be stored for 6~8 hours at the test temperature				

## 4. BMS

### 4.1 BMS System Schematic Diagram

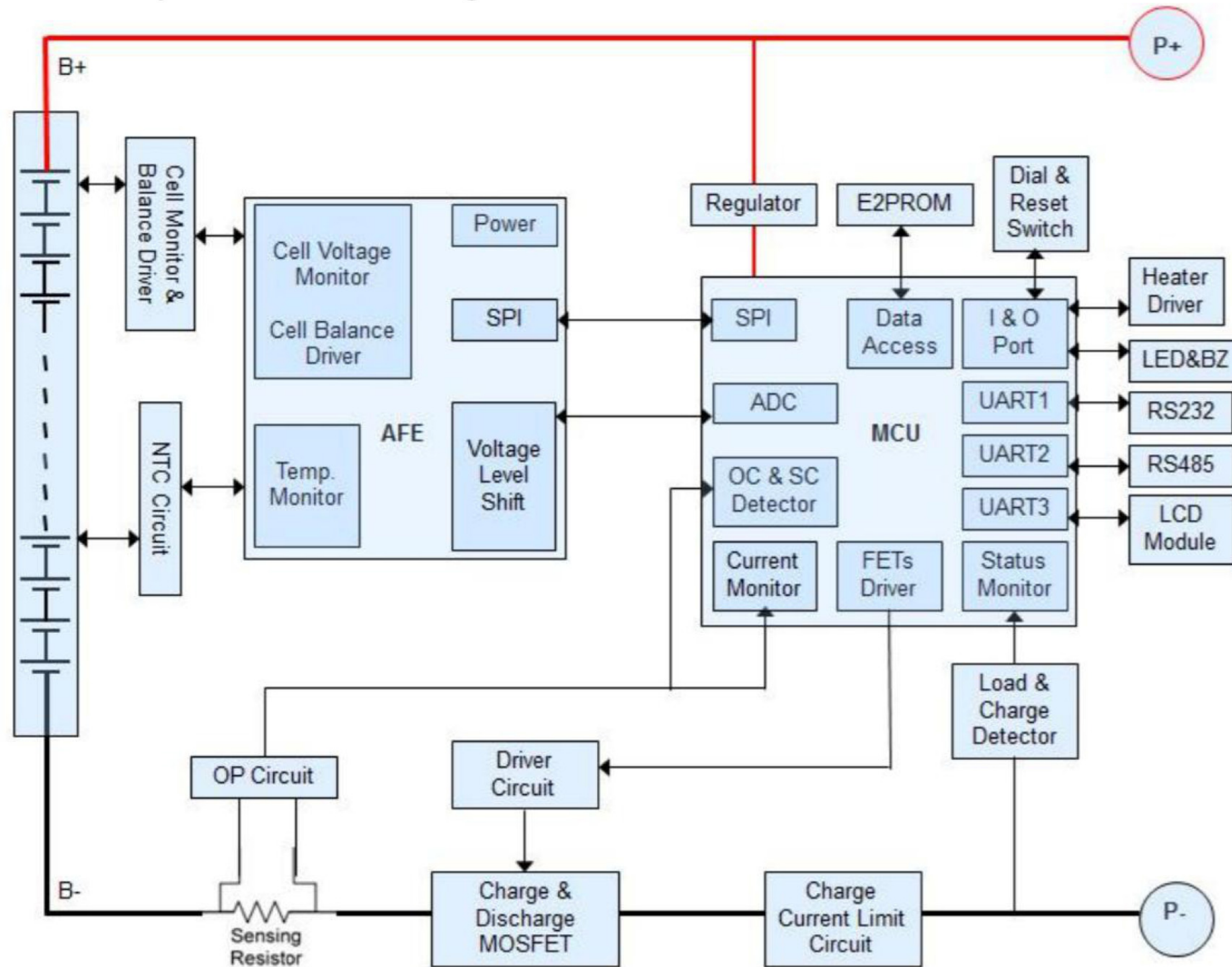

### 4.2 BMS Parameter

No.	Item	51.2V 50Ah	51.2V 100Ah	51.2V 150Ah	51.2V 200Ah	
1	Power Consumption	Low power consumption mode	≤100μA	≤100μA	≤100μA	
2	Over charge Protection	Over charge detection voltage	3.7V	3.7V	3.7V	
		Over charge release voltage	3.38V	3.38V	3.38V	
3	Over discharge protection	Over discharge detection voltage	2.7V	2.7V	2.7V	
		Over discharge release voltage	2.95V	2.95V	2.95V	
4	Over current protection	Charging over current detection current (detection time)	27.5A (1S)	55A (1S)	82.5A (1S)	110A (1S)
		Discharging over current detection current 1 (detection time)	27.5A 1S	55A 1S	82.5A 1S	110A 1S
		Discharging over current detection current 2 (detection time)	≥75A 100ms	≥150A 100ms	≥150A 100ms	≥150A 100ms
5	Temp. Protection	Detection temperature	65±2℃	65±2℃	65±2℃	65±2℃
6	Balance	Balance voltage	3.55V	3.55V	3.55V	3.55V

## 5. Product Life

The design life of this product is 10 years.

## 6. Transportation

During transportation, please keep the battery from acutely vibration, impacting, over-exposure to the sun and drenching.

## 7. Storage

### 7.1 Storage environment requirement

Under temperature of  $25\pm 2^{\circ}\text{C}$  and relative humidity of 45~85%.

### 7.2 Storage term

The lithium battery must be charged every six months, and a complete charging and discharging period is required in every nine months.

## 8. Cautions

- ※The installation and debugging should be operated by professional electric personnel.
- ※Please do not stick your hands or other objects deep into the interior of the product.
- ※Please do not open the product without a professional around.
- ※Please do not mechanically damage the battery module of the energy storage cabinet (perforation, deformation, peeling, etc.).
- ※Please use dry powder extinguisher as extinguishing agent.
- ※Please do not let the storage cabinet battery module contact abnormal metals or conductors.
- ※Please do not use the product after short circuit occurs.
- ※Please do not expose the energy storage cabinet to flammable or hazardous chemicals or vapors.



---

## **Shenzhen Max Power Co.,Ltd**

Add : 3F, A2 Block ,Guangming S&T Park,China Merchants, No.3009 Guanguang Road ,

Guangming District ,Shenzhen ,China

Web: [www.szmaxpower.com](http://www.szmaxpower.com)

Tel : 0755—23696504

Email : [info@szmaxpower.com](mailto:info@szmaxpower.com)

